

PLe
According to
EN ISO 13849-1

Note: The stated PL is only valid if all relevant requirements according to EN ISO 13849-1/-2 are met. It is the responsibility of the machine builder to make a risk assessment and make sure that the appropriate functional safety levels are achieved.

Anmärkning Remark	SSR20M general					Konstr Design	Godk Appr	Datum Date	Blad Sheet
						ABB		20210706	
						Ritad Drawn	Sidor Pages	Ritn nr Drawing no	Forts Cont
				ABB		2TLC010010T0001			

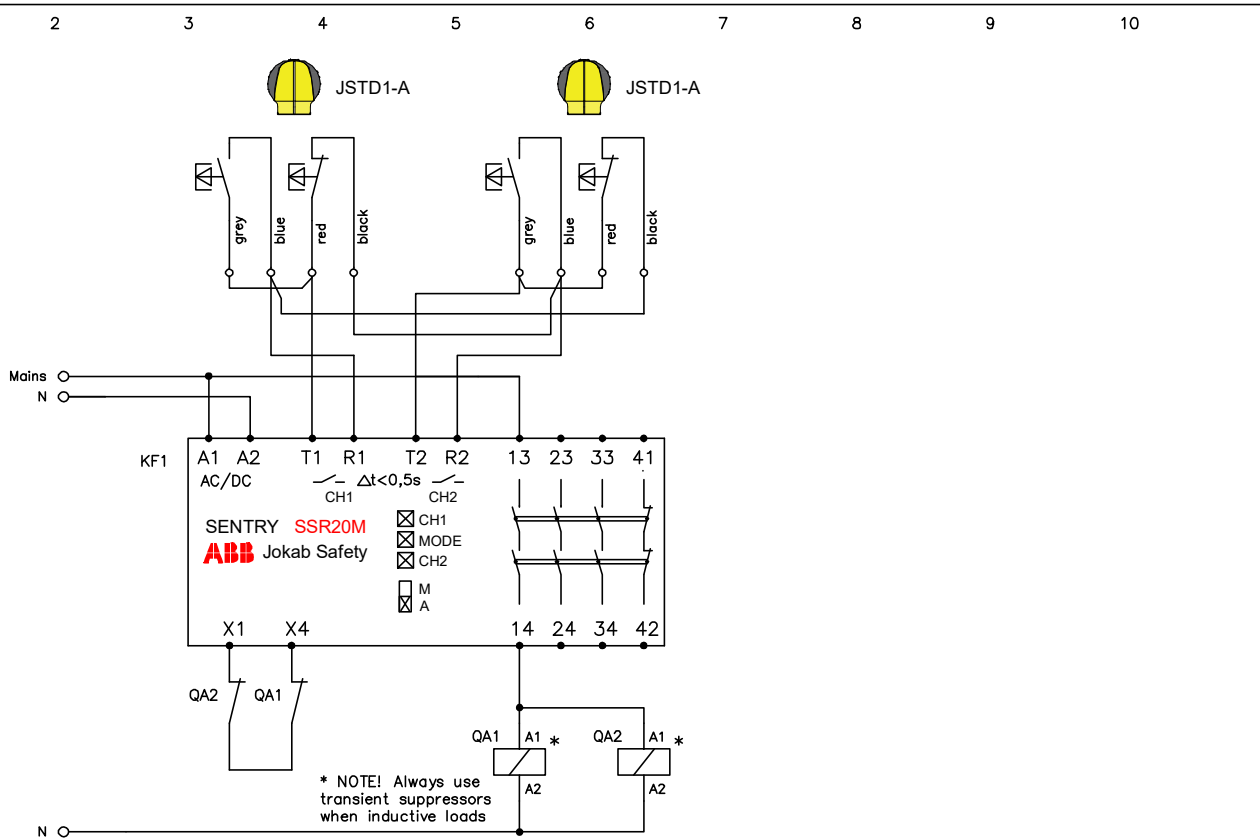

PLe
According to
EN ISO 13849-1

Note: The stated PL is only valid if all relevant requirements according to EN ISO 13849-1/-2 are met. It is the responsibility of the machine builder to make a risk assessment and make sure that the appropriate functional safety levels are achieved.

Anmärkning Remark	SSR20M with JSTD1-A	ABB Safety Products	Konstr Design	Godk Appr	Datum Date	Blad Sheet
			ABB		20210706	
			Ritad Drawn	Sidor Pages	Ritn nr Drawing no	Forts Cont
			ABB		2TLC010010T0002	